

Name

Date

Track

Event

Héligon Vincent

31/01/09/07

Piste Terre défoncée

**Front Suspension**

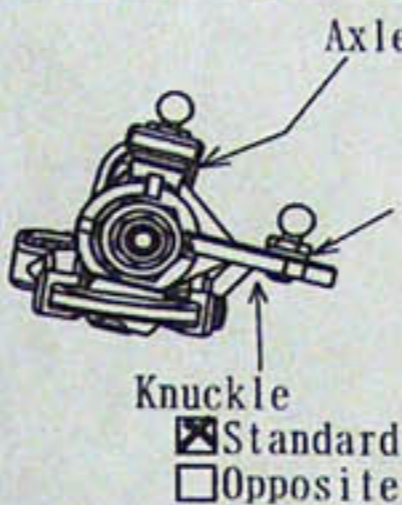
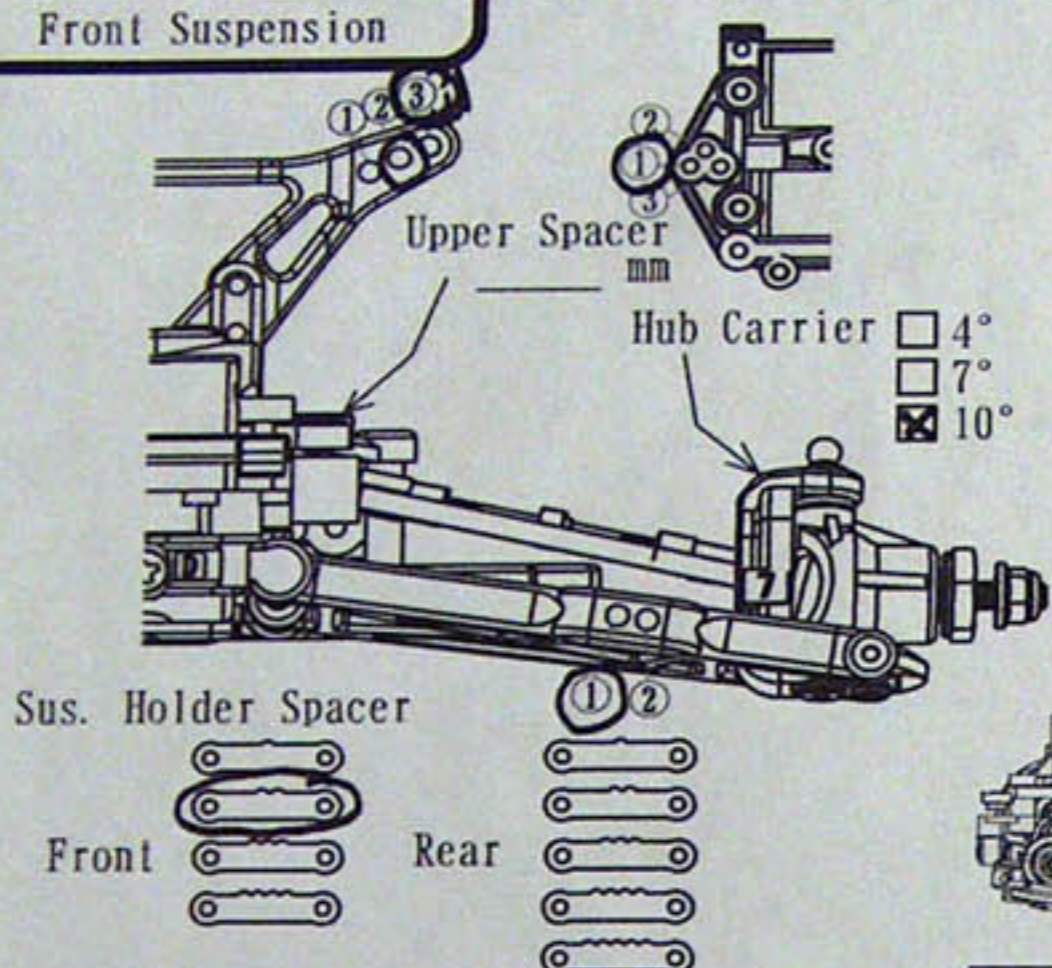

Camber Angle 11°  
Toe Angle 11°  
Sway bar None

Front Diff.  
 Rigid  
 Oneway  
 Diff.

Clear  
Print

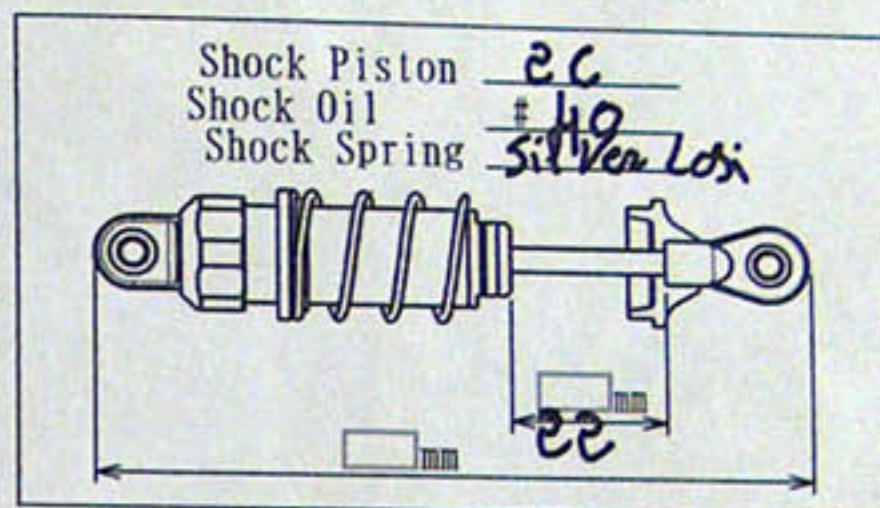

**Rear Suspension**

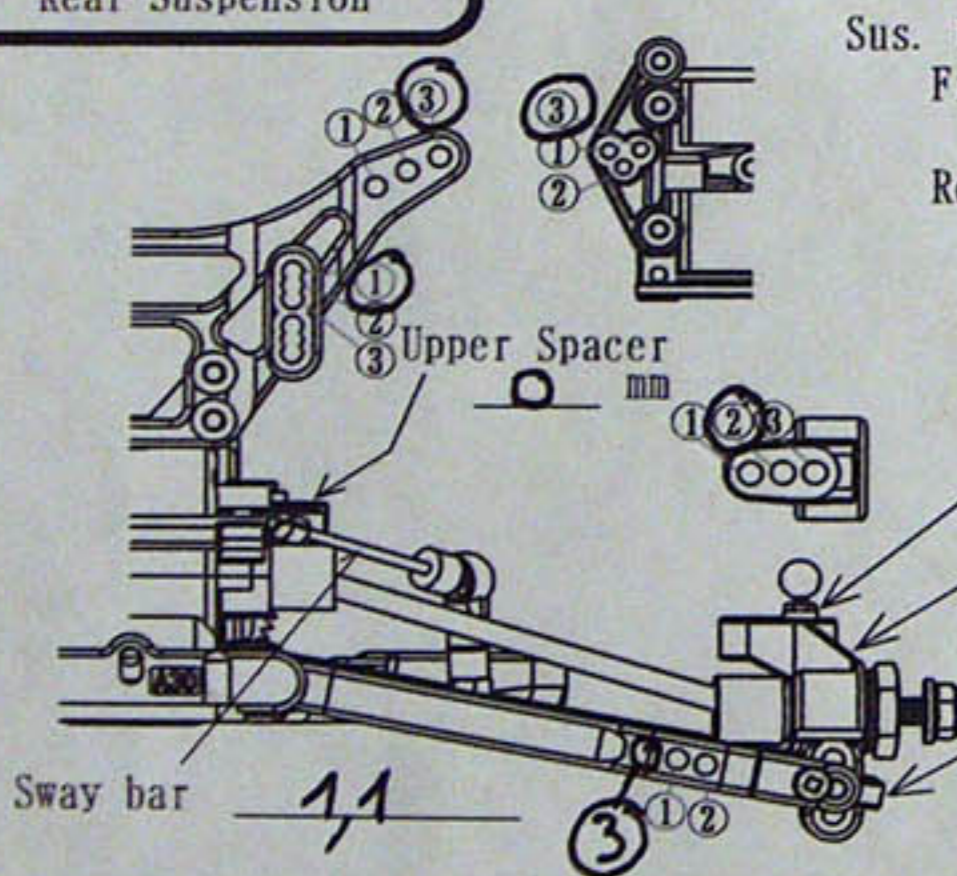

Sus. Holder Front  BF  
 BR  
Rear  A15  
 A25  
 A30

Sus. Holder Spacer Front \_\_\_\_\_ Rear \_\_\_\_\_

Ride Height 11 mm

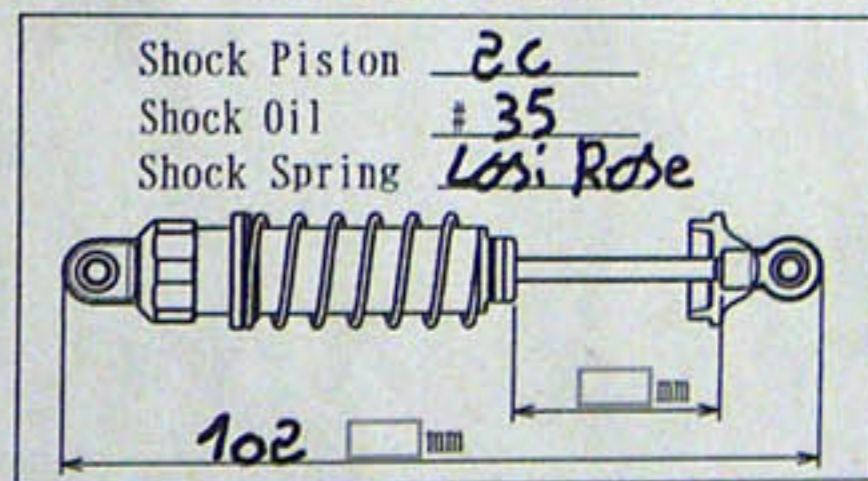

**Tire**

Front Tire Block Head Red  
Rear Tire Losi IF max Pin Red  
Front Inserts Losi  
Rear Inserts Losi

**Compound**

**Other**

Motor Locally 4X2  
Pinion/Spur 18°/78  
Wing \_\_\_\_\_  
Wing Angle  0°  7°  
 4°

**Center Shaft**

Oneway  
 Direct  
Slipper Sheet  Red-White  
 Red-Red  
 White-White

**Track Condition**

Smooth  Dry  
 Bumpy  Wet  
 Low Traction  Dusty  
 Med. Traction  Indoor  
 High Traction  Outdoor

**Spring Rate**

#50	Black	#68	Blue
#55	Orange	#70	Silver
#60	Orange Yellow	#75	Light Green
#65	Yellow	#80	Green

**Gear Ratio**

Secondary Gear Ratio 2.5 (16:40)

	16	17	18	19	20	21	22	23	24	25
76		11.18	10.56	10.00	9.50	9.05	8.64	8.26	7.92	7.60
78	12.19	11.47	10.83	10.26	9.75	9.29	8.86	8.48	8.13	7.80

**Shock Piston**

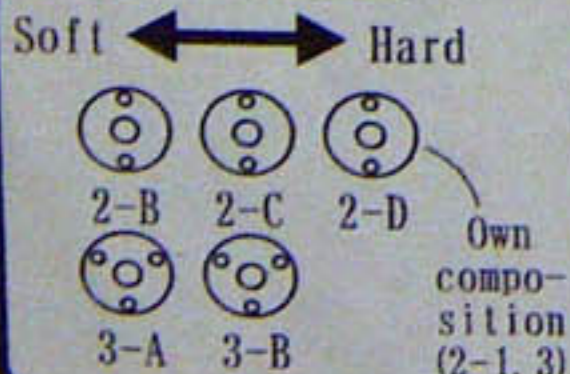

**Sway Bar**

1.0	Nickel
1.1	Gold
1.2	Silver
1.3	Copper
1.4	Black
1.5	Golden
1.6	Chromium

**Comments**

Essai classi KMRC, Empattement Rallongé de 6mm

