

Setup Sheet

Track: MRCI (France) European Championship 2005

Driver: Hönig

Date: Euro Champ 2005

- Indoor
- Smooth
- Slippery
- Outdoor
- Rough
- High-Bite
- Tight / Open
- Blue-Groove

FRONT SUSPENSION

(Circle or Check the Appropriate Settings)

Toe In Out _____ °

Ride Height Arms level

Camber - + 1.5 °

Caster Stock Other _____ °

Sway Bar No Yes size _____

of washers under steering / tie-rod ball studs

Spindle ball stud: _____

Bellcrank ball stud: _____

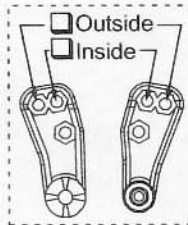

of washers under ball stud

- 1
- 2
- 3

Front Shocks

Oil: 30

Piston: 56 Standard / Drilled

Spring: blue

Limiters: Inside- Outside-

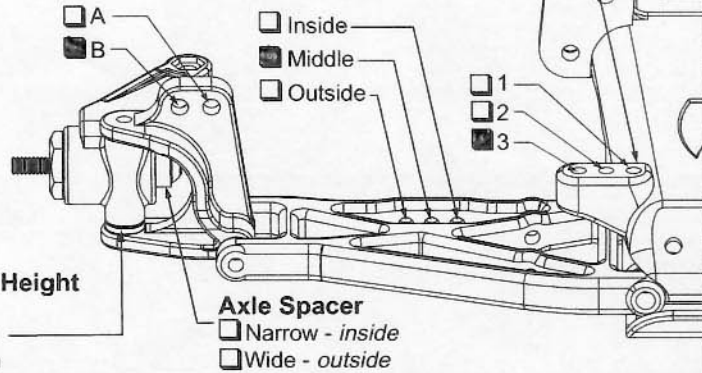

Spindle Height

- Top
- Middle
- Bottom

Axle Spacer

- Narrow - inside
- Wide - outside

REAR SUSPENSION

Toe-In Inside Outside _____ °

Pivot Support No Shim Shim Under Front Shim Under Rear > # of shims: _____

Ride Height Dogbones level

Camber - + 1.5 °

Drive Shafts Dogbones Aluminum CVDs Steel

Rear Hub Spacing Forward Center Rear Outdrives Steel Plastic

Sway Bar No Yes size _____



Rear Shocks

Oil: 27 1/2

Piston: 56 Standard / Drilled

Spring: red

Limiters: Inside- Outside-

Wing Position

- Forward
- Back

Wing Mount

- Top
- Bottom

- 4
- 3
- 2
- 1

- 1
- 2
- 3

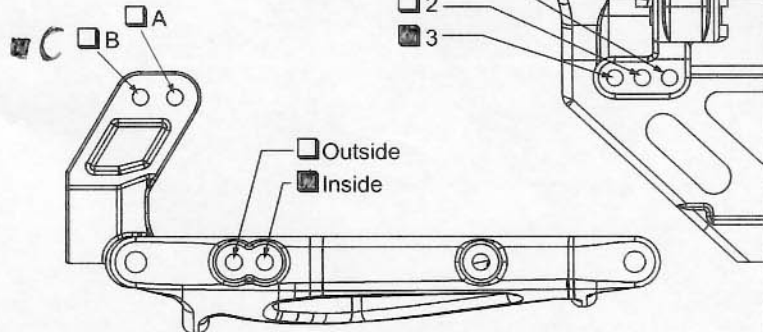

Tires Compound Foam

Front: _____

Rear: Schumacher Mini Spike Yellow

Motor: 11x2URP Pinion/Spur: 84/22

Battery Position: _____

Notes: used front wing 3rd at Euro-Champ 2005 in France (MRCI)